



VERTICAL DOORS, INC.™
VerticalDoors.com
Simply Uplifting™

542 3rd St. Lake Elsinore, CA 92530

TEL: (951) 273-1069, FAX: (951) 273-1854



CADILLAC ESCALADE 2007-UP

U.S. PATENTS

#6,808,223; #6,845,547; #7,140,075; #7,059,655

PATENTS AGGRESSIVELY ENFORCED!

**PLEASE CAREFULLY READ ALL INSTRUCTIONS BEFORE
ATTEMPTING TO INSTALL THIS PRODUCT.**

**FOR QUESTIONS PLEASE
CONTACT US AT (951) 273-1069**

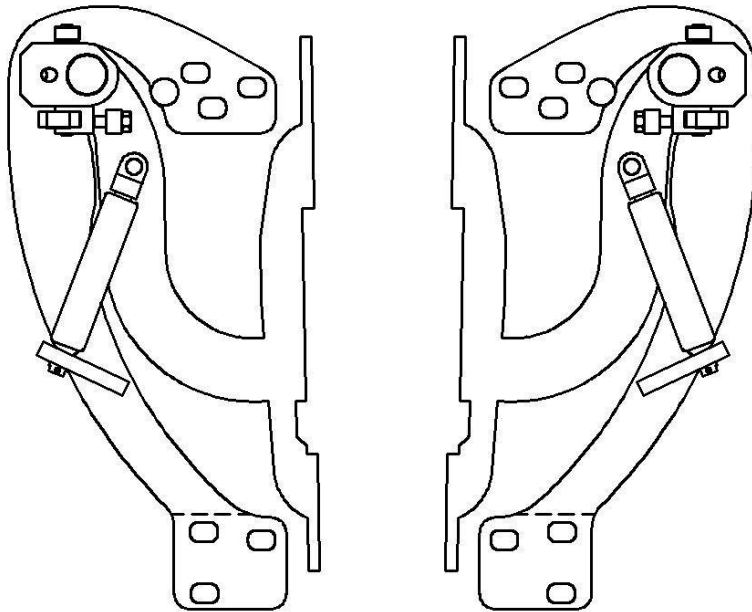

THIS KIT INCLUDES:

- 10 M8-1.25X30MM BOLTS WITH WASHERS
- 6 M8-1.25X40MM BOLTS WITH WASHERS
- 2 SHOULDER BOLTS WITH WASHERS
- RIGHT AND LEFT HINGE ASSEMBLY
- 2 SHOCKS 720 PSI
- 2 PINS

TOOLS REQUIRED FOR INSTALLATION:

	<ul style="list-style-type: none"> ➤ AIR RACHET, GRINDER AND CUTTER.
	<ul style="list-style-type: none"> ➤ 7MM, 8MM, 10MM, 11MM, 13MM, SOCKETS AND EXTENSION.
	<ul style="list-style-type: none"> ➤ FORK AND PHILLIP'S SCREW DRIVERS
	<ul style="list-style-type: none"> ➤ SPACERS FOR THE DOOR GAP.
	<ul style="list-style-type: none"> ➤ 3/16 ALLEN WRENCH
	<ul style="list-style-type: none"> ➤ 1/4 TORX BIT
	<ul style="list-style-type: none"> ➤ 9/16 WRENCH
	<ul style="list-style-type: none"> ➤ LOCKTITE RED

OTHER TOOLS MAY BE NEEDED DEPENDING ON YOUR VEHICLE.

(Note: The pictures on the manual are for reference only they may not match your vehicle.)

1) Disconnect the battery.

2) Remove fender:

Remove all the 7mm bolts and the plastic clips from the wheel well.

Remove the 13mm bolts securing the hood brackets, (You will need a helper) then remove the hood.

After removing the battery remove all the bolts securing the battery base to the fender.

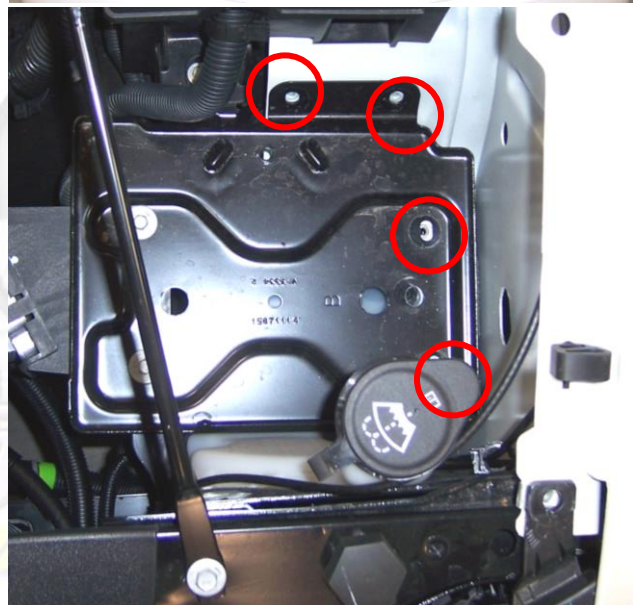
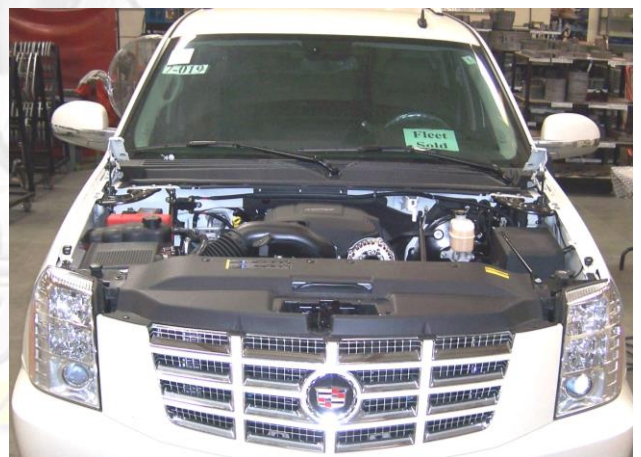

Remove the support bracket securing the fender.

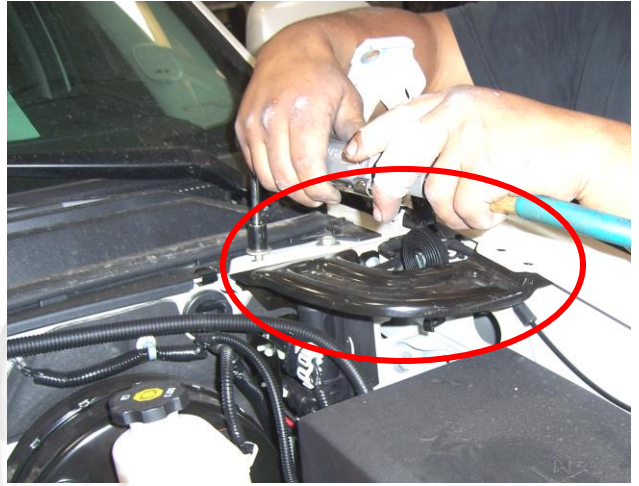

You will need to loosen the fuse box, start by pulling the handles up, then removing the bolts securing it. *(The reason you need to loosen it is to gain access to the bracket and bolts at the bottom of the fender)*

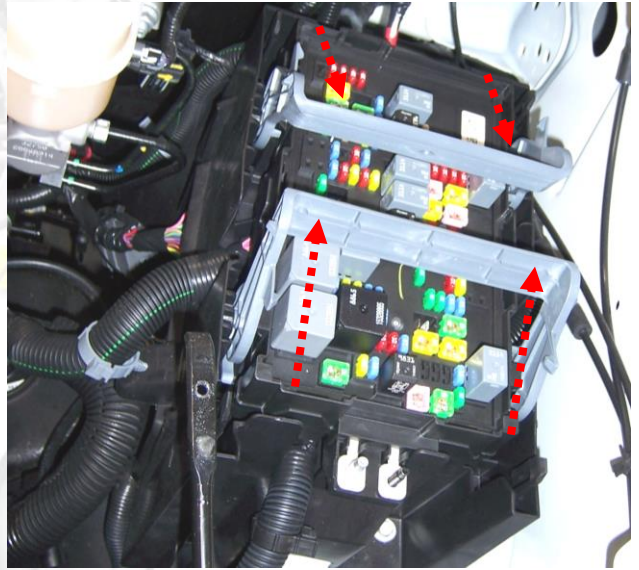

Loosen the (2) 10mm nuts securing the fender bracket.

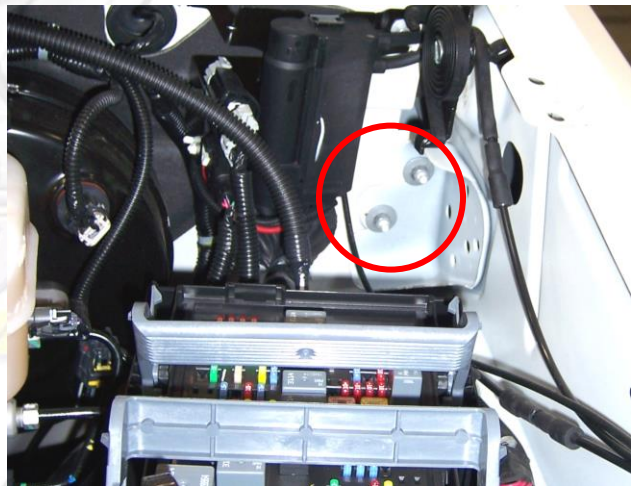

Make sure you remove all the wires hoses and anything else that may be attached to the fender.

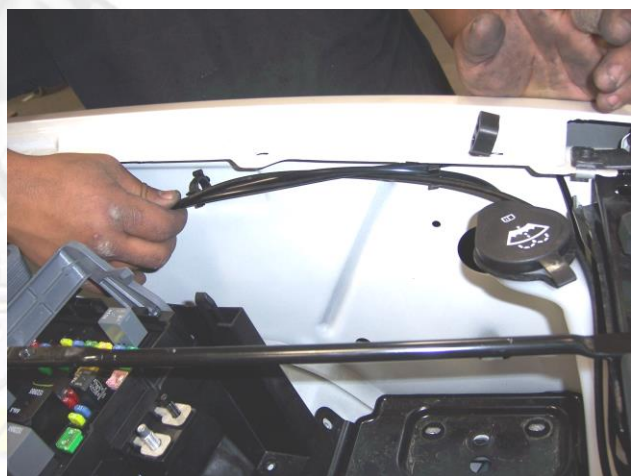

Open the door and remove (2) 10mm bolts that are located on the factory hinges.

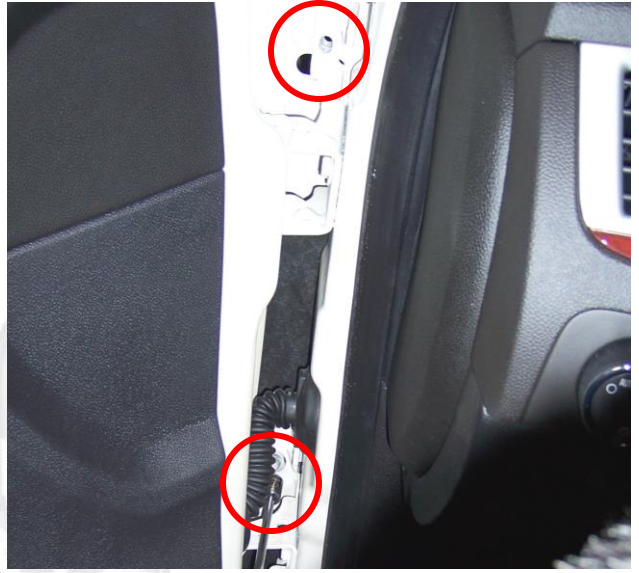

Remove (1) 10mm bolt from the bottom of the fender by the door.



You will need to remove the plastic cover as shown by remove (9) Plastic clips.

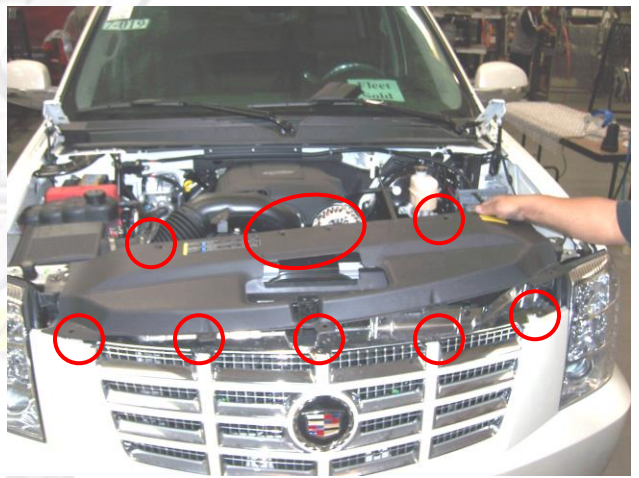

After removing the plastic cover you will be able to remove the headlight, to gain access to (3) 10mm bolts securing the front of the fender to the body.

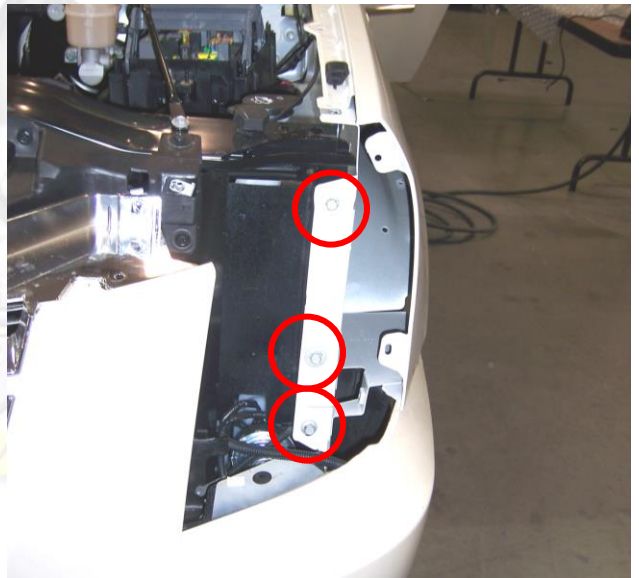

With the wheel well loose pull on it and remove (2) 10mm bolt securing the fender to the bumper. After removing the bolts you will be able to remove the plastic bracket.



Pull on the bumper and remove (1) 13mm bolt securing the fender to the body. Now you will be able to remove the fender, make sure you have removed everything from the fender.

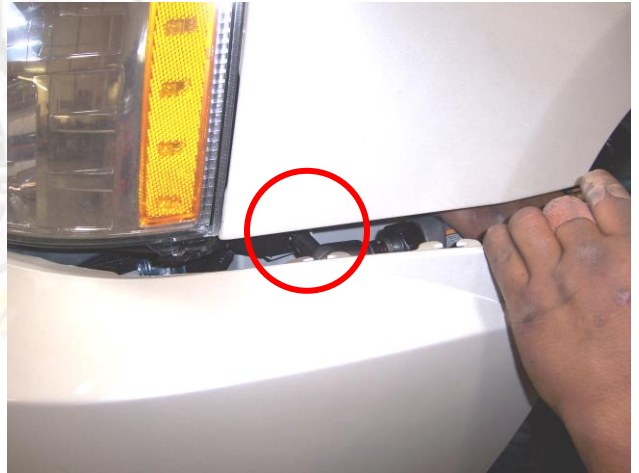

3) You will need to more wire slack: Remove the foot guard and the kick plate, this will give you access to the wire harness that goes to the door you will need to remove any hold down clips to gain more wire slack.

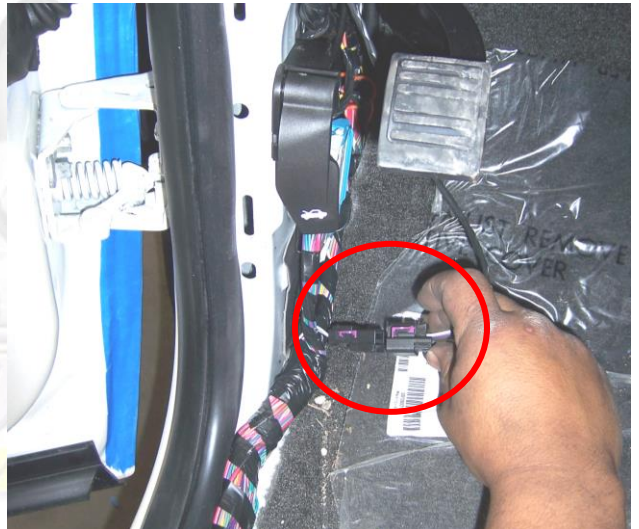

Remove the side cover from the dash board to gain access to a wire harness clip which you will have to remove to gain more wire slack. After removing the clips replace the kick plate and the foot guard.



5) Close door and use painter's tape to secure the door in preparation for factory hinge removal.

Use a 13mm socket to remove the factory hinges.

Hint (You can make your spacer out of paint sticks and about 8-10 turns of blue painters tape)*

Install the spacers after removing the factory door hinges.

6) Install new Vertical Doors Inc. system:

Make sure the new VDI system sits flat against the apron.

Hint Tighten the bolts on the door first and then install the bolts on the body.*

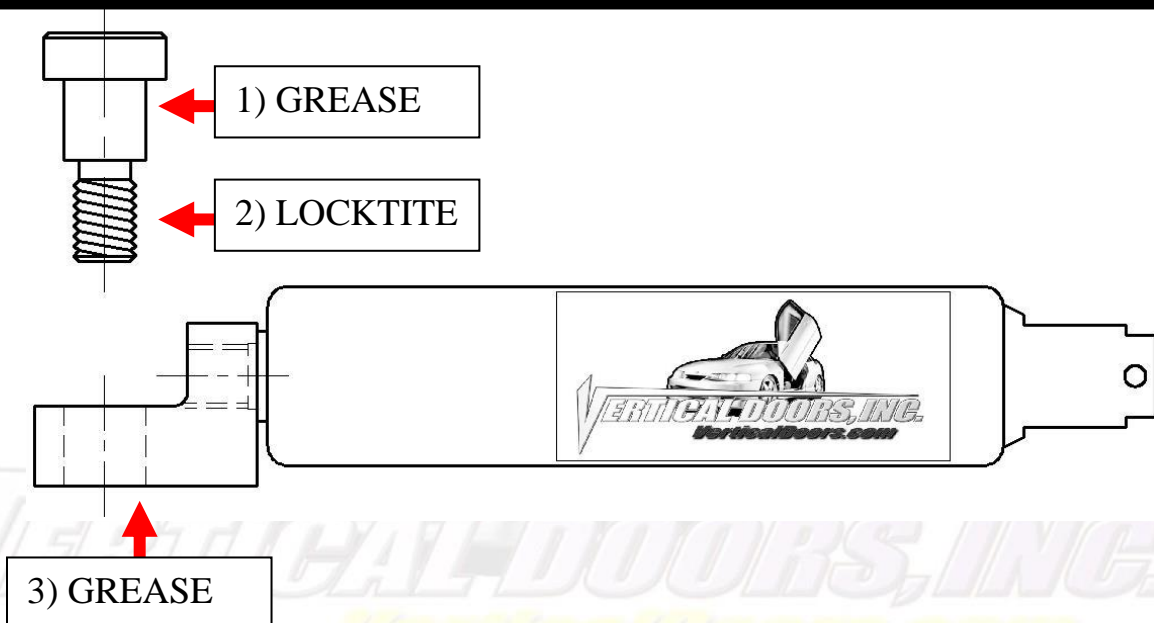
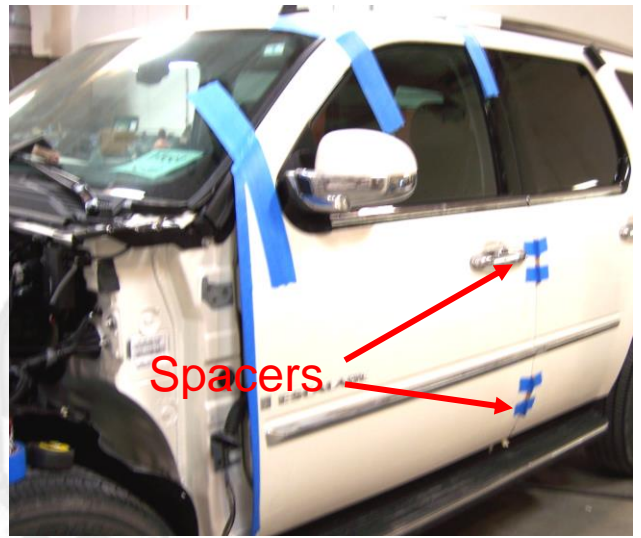

***IMPORTANT STEP: DO NOT SKIP THIS STEP. THIS STEP IS CRUCIAL IN YOUR INSTALLATION PROCESS, IF THIS STEP IS NOT COMPLETED WHEN INSTALLING THE VERTICAL DOOR KIT; ALL WARRANTIES ARE VOIDED, AND MAY CAUSE FUTURE PROBLEMS WITH YOUR VERTICAL DOOR SYSTEM.**

1ST, make sure you put grease on the body of shoulder bolt where the arrow is pointing.

2ND, make sure you put red Locktite, where the arrow is pointing, on thread of shoulder bolt.

3RD, make sure you put grease on the bottom side of the shock end.

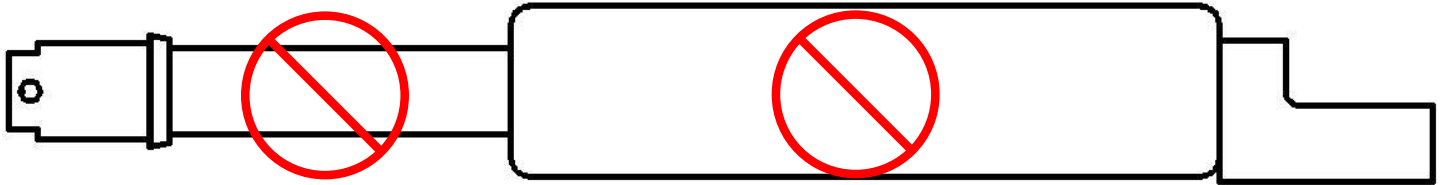

WARNING! THE USE OF ANY TYPE PLYERS, PAINT OR FOREING MATERIALS ON THE SHOCK'S BODY OR SHAFT WILL VOID THE WARRANTY.

7) Once hinge is locked in place, break nut #1 then turn Allen set screw #2 on fig until it hits the block then open the door and continue to adjust until the door matches with the striker, open and

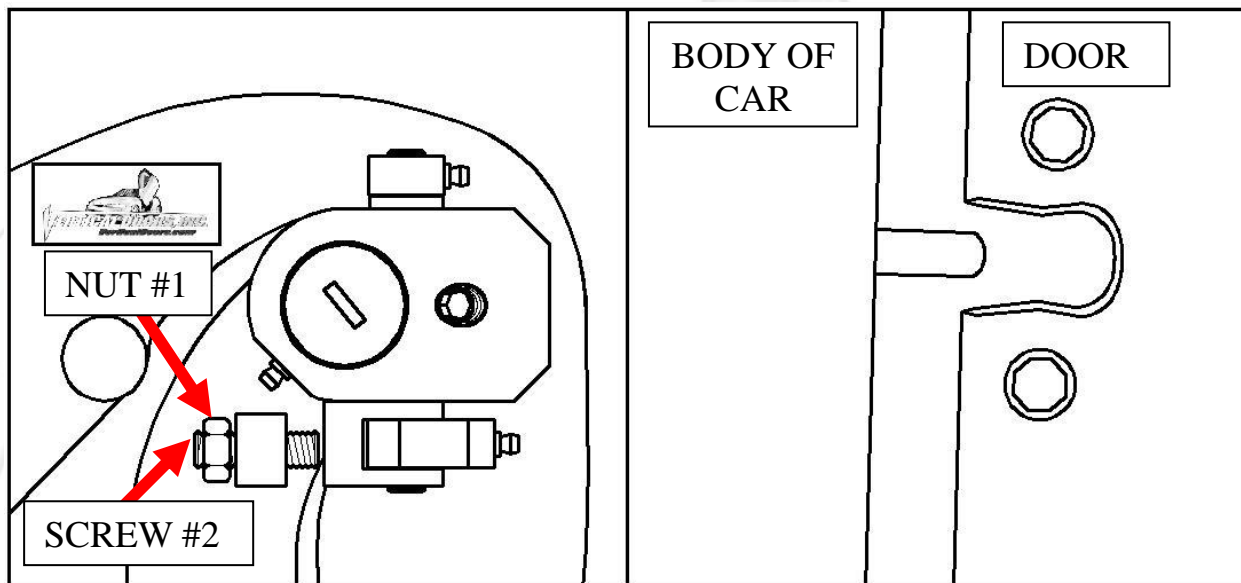

close door making sure it closes like factory.

Hint(leave #1 nut loose until shock is installed Allen set screw will have to be re-adjusted after shock is installed.*

8) Install the shock.

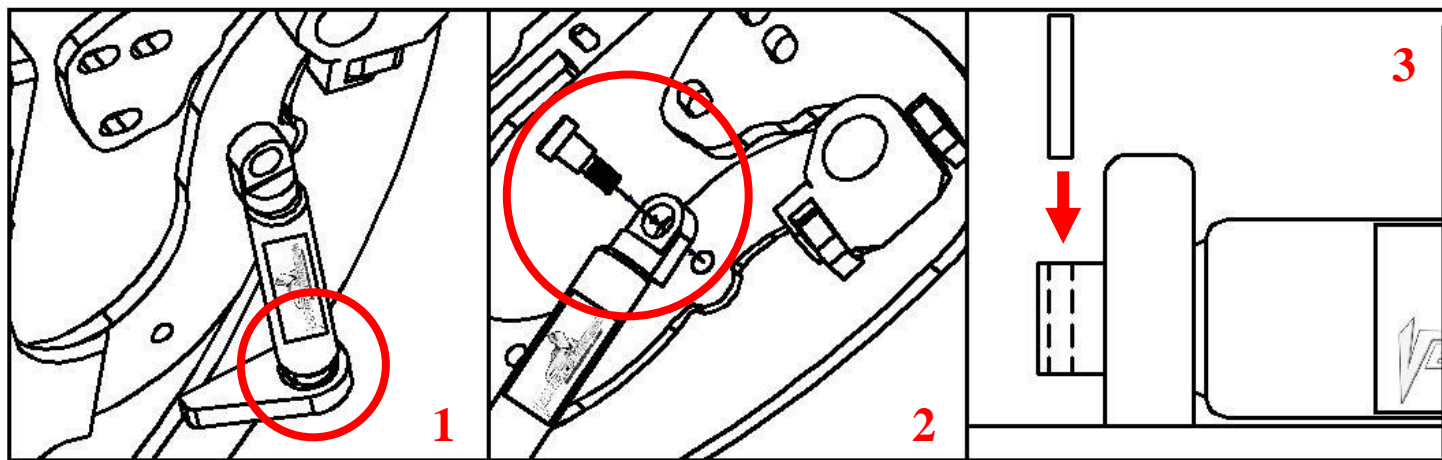

Hint (You will need a helper to raise the door). (Slip the spherical rod mount into the spherical ball bearing (1). Using a 1/4 Allen wrench, tighten the screw into the swing arm (2). After the shock is installed secure it by installing the pin in the bottom shock end (3).*

9) After shock is installed re-install door panel and lift the door. Adjust door opening screw #3 clockwise until distance between nub and swing arm is enough so that the swing arm moves up and down freely.

Hint (Fine tune the Allen Adjustment screw (#2) to realigned striker with door. After the door is align test door by opening and closing, lifting and lowering door several times.*

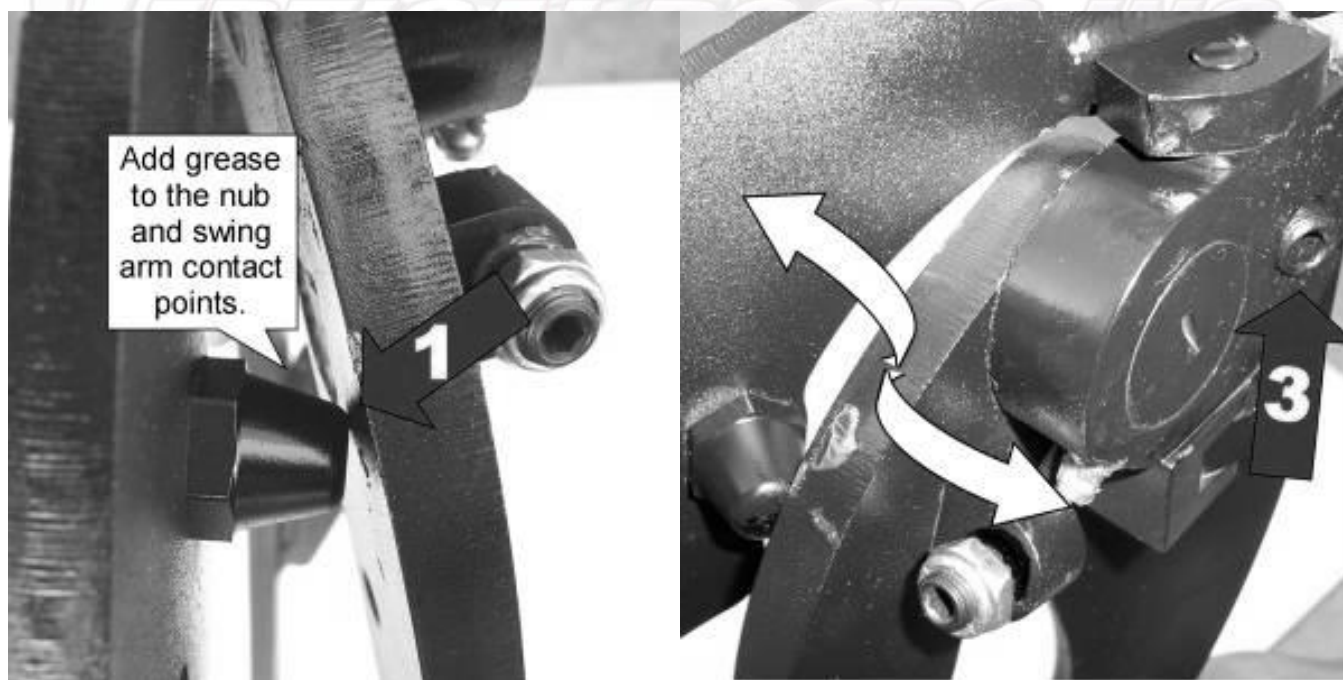

VerticalDoors.com

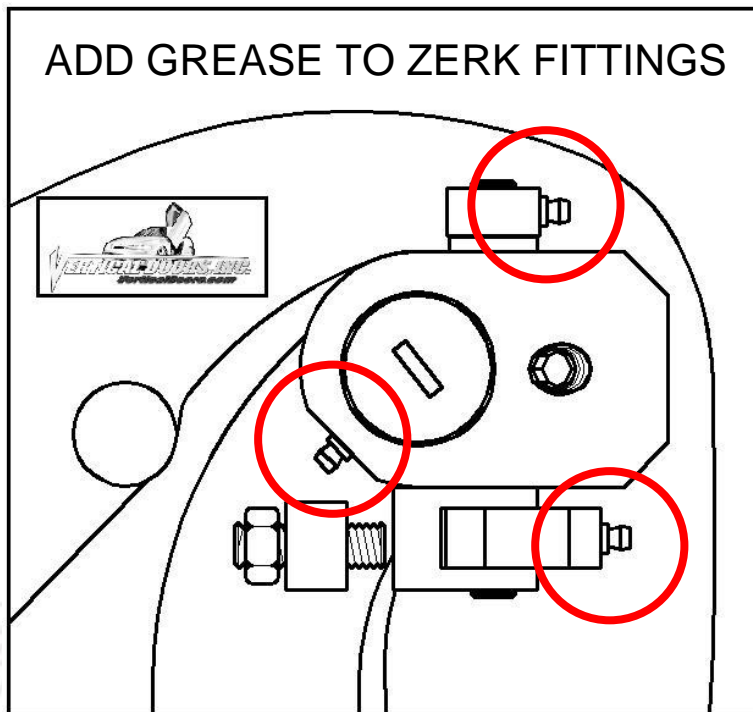

Note: Do not install fender until the adjustment of the door is accurate, and the set screw is tightly secure. Also make sure everything is tight, adjustment is set and everything is Loctite.

10) Modify factory wire loom:
In order to be able to open and raise the door, cut the factory wire boot and add wire loom to protect exposed wires.



VERTICAL DOORS, INC.
VerticalDoors.com

11) Cut the inner lip of your fender to make room for the new Vertical Doors hinge. Note: After you have cut the fender use a sander or grinder and make sure the surface is completely flat.



12) Close the door and replace the fender by reversing step 2.

Hint(Make sure the electrical wires don't get pinched enough to damage wires)*

13) For the other side just follow steps 2-12.

VERTICAL DOORS, INC.
VerticalDoors.com

VERTICAL DOORS, INC.
VerticalDoors.com

Thank you for your purchase of the
CADILLAC ESCALADE 2007

VERTICAL DOORS INC. SYSTEM

Simply Uplifting



NOTE:

Vertical Doors Inc. assumes no responsibility for any damages caused by improper installation